

	6" Duct (Standard): 200 CFM/1.0 Sone(Estimate) @ 0.1 SP, 17.5 Watts 163 CFM/1.3 Sones(Estimate) @ 0.25 SP, 21.5 Watts		
--	--	--	--

Description

Low noise ceiling mount ventilating fan rated for continuous running. ENERGY STAR® Most Efficient 2016. HVI, UL and cUL certified to comply with ASHRAE 62.2 local and whole building continuous and intermittent operation. Meets CA Title 24 requirements.

DC Motor/Blower

- Power rating of 120 volts/60Hz
- DC brushless motor engineered to run continuously
- Motor equipped with thermal cutoff fuse
- Removable with permanently lubricated plug-in motor
- Built-in soft start function to increase bearings' life
- Automatically powers OFF when impeller is locked abnormally

Housing

- Galvanized steel body
- Detachable 6" diameter metal duct adapter
- Built-in backdraft damper
- Easy installation with suspension bracket

Grille

- Attractive design using ABS material
- Attaches directly to housing with torsion springs

LED Indicator

- Turn the power switch on/off to operate on/off. LED indicator will be green when power is on

Warranty

- 3-year limited warranty

TYPICAL SPECIFICATION

Ventilation fan shall be Delta Breez model Pro200; ENERGY STAR qualified with DC brushless motor engineered to run continuously for a minimum 70,000 hours; airflow rating of 200 CFM and loudness rating of 1.0 Sones at 0.1 static pressure as certified by the Home Ventilating Institute (HVI); power consumption of 17.5 Watts with efficiency rating of 11.4 CFM/Watt at 0.1" static pressure; fan will feature LED indicator running light and motor lock protection; fan shall be UL/cUL listed for use over a bathtub or shower when installed in a GFCI protected branch circuit.

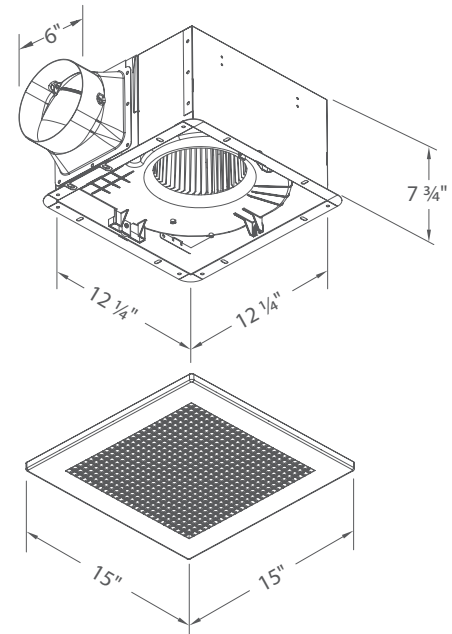

Fan Curve

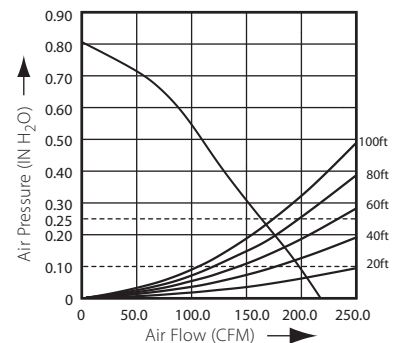

BreezPro Pro200	6" Duct (Standard)	
Static Pressure (inches w.g.)	0.1	0.25
Air Flow (CFM)	200	163
Sones	1.0	1.3
Power Consumption (Watts)	17.5	21.5
Energy Efficiency (CFM/Watt)	11.4	7.5
Current (Amps)	0.52 Max	
Power Rating (V/Hz)	120 / 60	

Tag	Quantity	Comments	Project:
			Location:
			Architect:
			Engineer:
			Contractor:
			Submitted by:
			Date: